

Dr Oliver Mathematics
Mathematics: National Qualifications N5
2016 Paper 2: Calculator
1 hour 20 minutes

The total number of marks available is 50.

You must write down all the stages in your working.

1. A drinks manufacturer is reducing the sugar content of one of their fizzy drinks by 8% per year over the next 3 years. (3)
The sugar content of a standard can is currently 35 grams.
Calculate the sugar content of a standard can after 3 years.
2. A pollen sample weighs 12 grams and contains 1.5×10^9 pollen grains. (2)
Calculate the weight of one pollen grain in grams.
Give your answer in scientific notation.
3. The diagram below shows parallelogram $ABCD$. (1)

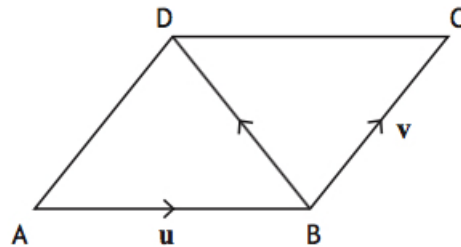

\overrightarrow{AB} represents vector \mathbf{u} and \overrightarrow{BC} represents vector \mathbf{v} .

Express \overrightarrow{BD} in terms of \mathbf{u} and \mathbf{v} .

4. Factorise fully (2)
 $3x^2 - 48$.
5. The diagram below shows a circle, centre O . (3)

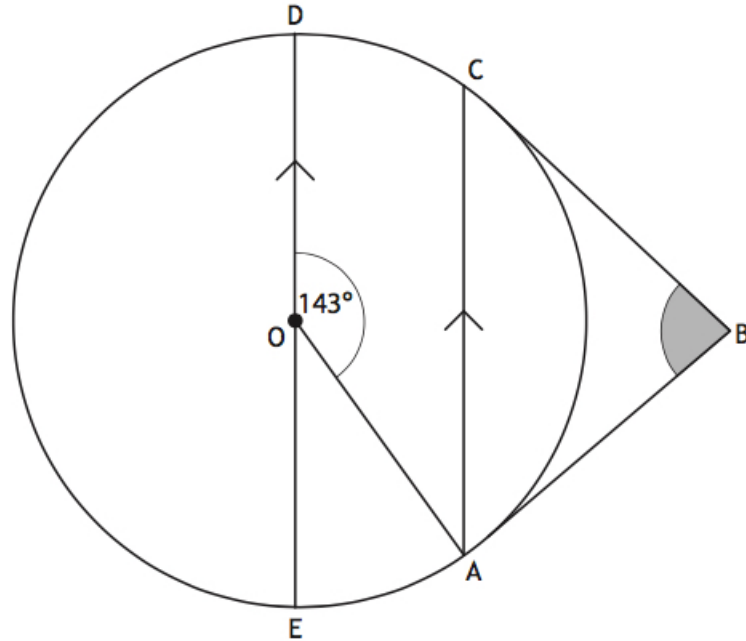

- AB and CB are tangents to the circle.
- AC and ED are parallel.
- Angle AOD is 143° .

Calculate the size of angle ABC .

6. Jack called his internet provider on six occasions to report connection problems.

On each occasion he noted the length of time he had to wait before speaking to an adviser.

The times (in minutes) were as follows:

13 16 10 22 5 12

- (a) Calculate the mean and standard deviation of these times. (4)

Sophie also called the same internet provider, on several occasions, to report connection problems.

Her mean waiting time was 15 minutes and the standard deviation was 4.3 minutes.

- (b) Make two valid comments comparing Sophie's waiting times with Jack's waiting times. (2)

7. A carton is in the shape of a large cone with a small cone removed. (5)
 The large cone has diameter of 32 cm and height 24 cm.
 The small cone has diameter of 18 cm and height 13.5 cm.

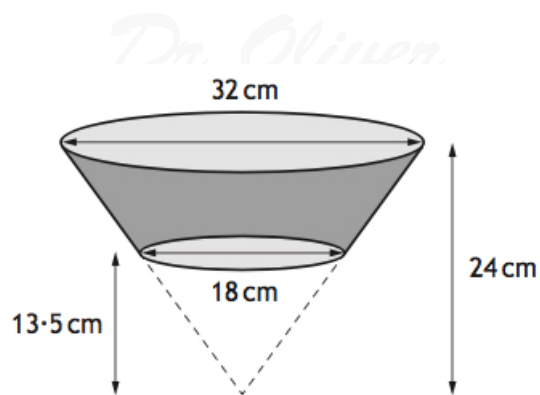

Calculate the volume of the carton.

Give your answer correct to 2 significant figures.

8. A set of stepladders has legs 150 centimetres and 140 centimetres long. (3)
 When the stepladder is fully open, the angle between the longer leg and the ground is 66° .

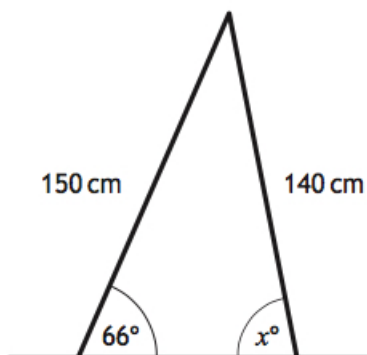

Calculate x° , the size of the angle between the shorter leg and the ground.

9. Express (2)

$$x^2 + 8x - 7$$

in the form

$$(x + a)^2 + b.$$

10. Simplify (3)

$$(n^2)^3 \times n^{-10}.$$

Give your answer with a **positive** power.

11. Two pictures are mathematically similar in shape. (3)



100 cm



60 cm

The cost of each picture is proportional to its area.

The large picture costs £13.75.

Find the cost of the small picture.

12. Change the subject of the formula (3)

$$L = \sqrt{4kt - p}$$

to k .

13. Express (3)

$$\frac{3}{x-2} + \frac{5}{x+1}, \quad x \neq 2, \quad x \neq -1,$$

as a single fraction in its simplest form.

14. Solve the equation (3)

$$2 \tan x^\circ + 5 = -4,$$

for $0 \leq x \leq 360$.

15. This perfume bottle has a label in the shape of part of a circle. (4)

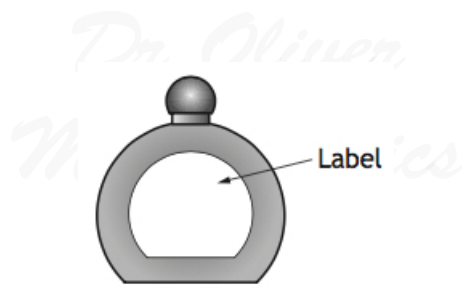

A diagram of the label is shown below.

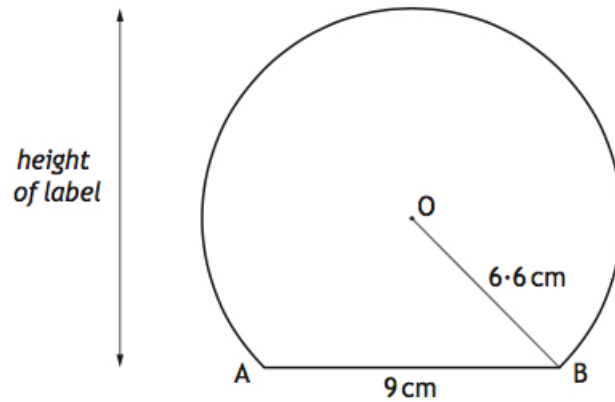

- The centre of the circle is O .
- The chord AB is 9 centimetres.
- The radius OB is 6.6 centimetres.

Find the height of the label.

16. In the diagram below:

- DE is perpendicular to AC .
- $AD = 4$ centimetres.
- $DB = 6$ centimetres.
- $AE = EC = 3$ centimetres.

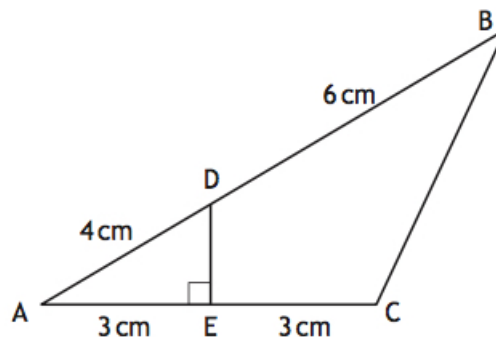

Calculate the length of BC .
Give your answer correct to one decimal place.

*Dr Oliver
Mathematics*

*Dr Oliver
Mathematics*

*Dr Oliver
Mathematics*

*Dr Oliver
Mathematics*

*Dr Oliver
Mathematics*

*Dr Oliver
Mathematics*