

Dr Oliver Mathematics
Mathematics: National Qualifications N5
2014 Paper 2: Calculator
1 hour 20 minutes

The total number of marks available is 50.

You must write down all the stages in your working.

1. There are 964 pupils on the roll of Aberleven High School. (3)
It is forecast that the roll will decrease by 15% per year.
What will be the expected roll after 3 years?
Give your answer to the nearest ten.
2. The diagram shows a cube placed on top of a cuboid, relative to the coordinate axes. (2)

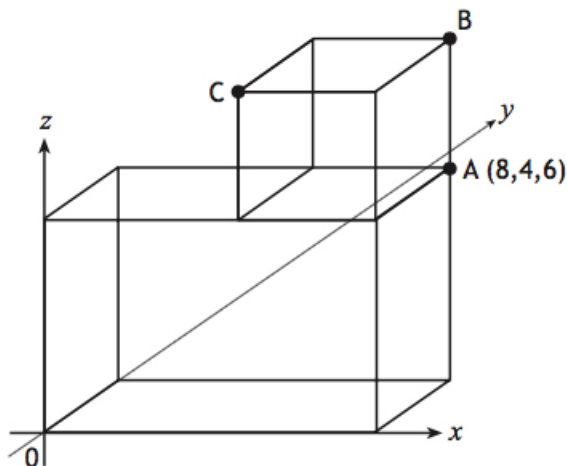

A is the point $(8, 4, 6)$.

Write down the coordinates of B and C .

3. Two groups of people go to a theatre.
Bill buys tickets for 5 adults and 3 children.
The total cost of his tickets is £158.25. (1)
(a) Write down an equation to illustrate this information.

Ben buys tickets for 3 adults and 2 children.
The total cost of his tickets is £98.

 - (b) Write down an equation to illustrate this information. (1)
 - (c) Calculate the cost of a ticket for an adult and the cost of a ticket for a child. (4)

4. A runner has recorded her times, in seconds, for six different laps of a running track.

53 57 58 60 55 56

(a) (i) Calculate the mean of these lap times. (1)

Show clearly all your working.

(ii) Calculate the standard deviation of these lap times. (3)

Show clearly all your working.

She changes her training routine hoping to improve her consistency.

After this change, she records her times for another six laps.

The mean is 55 seconds and the standard deviation 3.2 seconds.

(b) Has the new training routine improved her consistency? (1)

Give a reason for your answer.

5. A supermarket sells cylindrical cookie jars which are mathematically similar. (3)

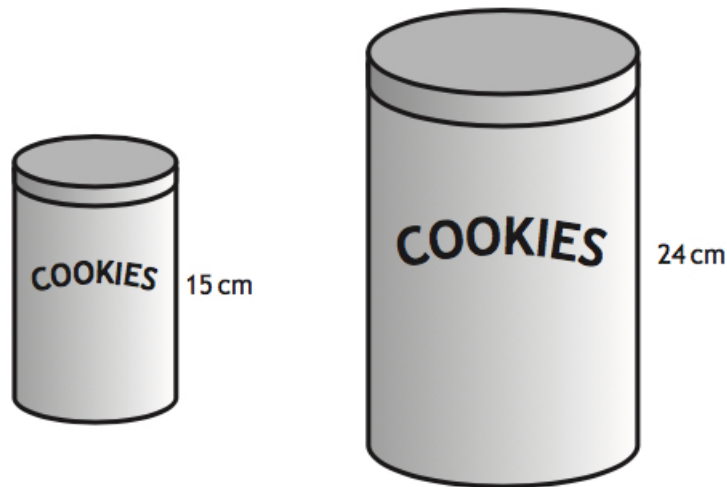

The smaller jar has a height of 15 centimetres and a volume of 750 cubic centimetres.

The larger jar has a height of 24 centimetres.

Calculate the volume of the larger jar.

6. The diagram below shows the position of three towns. (4)

Lowtown is due west of Midtown.

The distance from

- Lowtown to Midtown is 75 kilometres.
- Midtown to Hightown is 110 kilometres.
- Hightown to Lowtown is 85 kilometres.

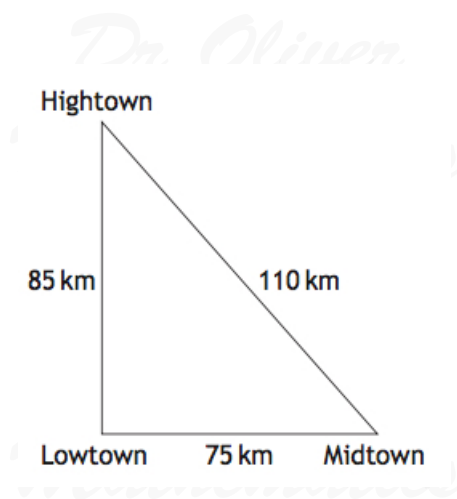

Is Hightown directly north of Lowtown?
Justify your answer.

7. An ornament is in the shape of a cone with diameter 8 centimetres and height 15 centimetres. (5)
 The bottom contains a hemisphere made of copper with diameter 7.4 centimetres.
 The rest is made of glass, as shown in the diagram below.

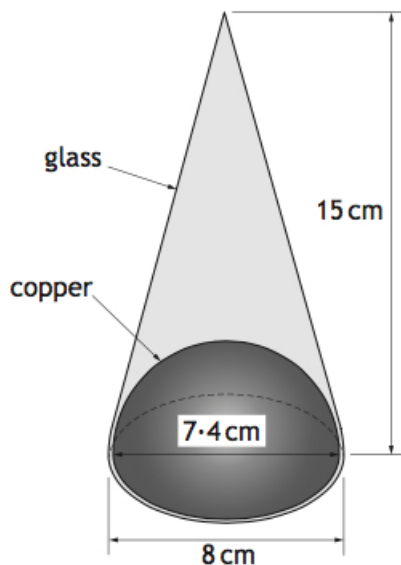

Calculate the volume of the glass part of the ornament.
 Give your answer correct to 2 significant figures.

8. Simplify (3)

$$\frac{n^5 \times 10n}{2n^2}$$

9. Express

$$\frac{7}{x+5} - \frac{3}{x}, x \neq -5, x \neq 0,$$

as a single fraction in its simplest form.

(3)

10. In a race, boats sail round three buoys represented by A , B , and C in the diagram below.

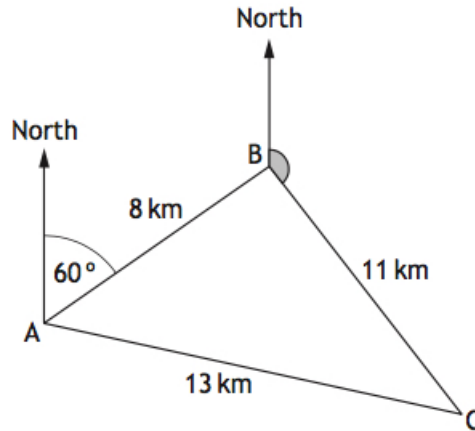

B is 8 kilometres from A on a bearing of 060° .

C is 11 kilometres from B .

A is 13 kilometres from C .

(a) Calculate the size of angle ABC .

(3)

(b) Hence find the size of the shaded angle.

(2)

11. Change the subject of the formula

$$s = ut + \frac{1}{2}at^2$$

to a .

(3)

12. Solve the equation

$$11 \cos x^\circ - 2 = 3,$$

for $0 \leq x \leq 360$.

(3)

13. The picture shows the entrance to a tunnel which is in the shape of part of a circle.

(5)

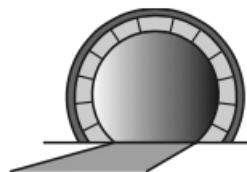

The diagram below represents the cross-section of the tunnel.

- The centre of the circle is O .
- MN is a chord of the circle.
- Angle MON is 50° .
- The radius of the circle is 7 metres.

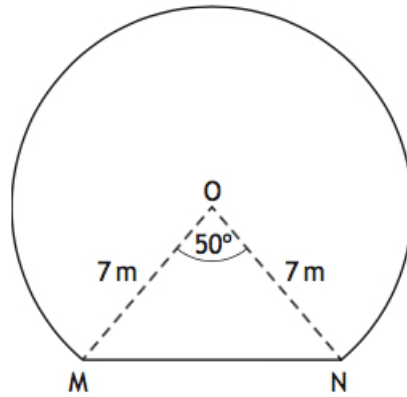

Calculate the area of the cross-section of the tunnel.